

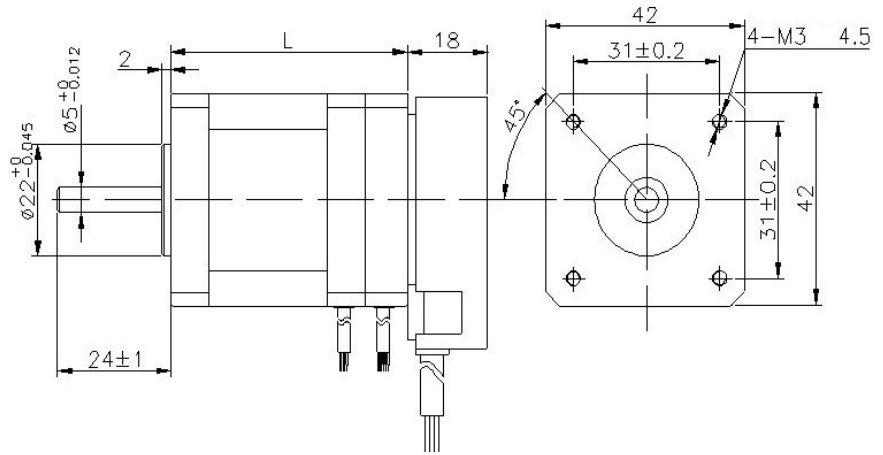

Illustrative Photo

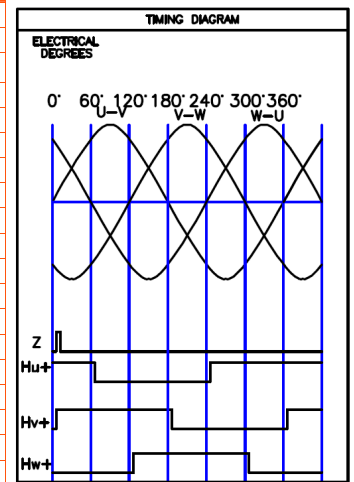

Motor Parameters					
Part No	BLM	4260	4280	42100	Remarks
Nominal power	W	31	62	94	
Nominal voltage	V	24	24	24	More voltage option
Nominal speed	rpm	3000	3000	3000	More speed options
Nominal torque	mNm	100	200	300	
Nominal current	A	10.5	2.7	3.8	
Weight	g	400	600	700	
Motor Length (L)	mm	68	87	106	
No load speed	rpm	3600	3600	3600	
No load current	mA				
Stall torque	mNm				
Starting current	mA				
Terminal resistance	ohm				
Terminal Inductance	mH				
Efficiency	%				
Torque Constant	mNm/A				
Back EMF Constant	mV/rpm				
No of Poles		8	8	8	Other Poles available



Phase diagram seen from output shaft

Planetary Gear Box Parameters (P4)									
Part No: -nnP6		-4P4	-13P4	-19P4	-27P6	-51P4	-70P4	-100P4	-140P4
Gear Ratio		3.7	13.7	19	27	51	70	100	140
Rated Torque	Nm	6	16	16	16	20	20	20	20
Peak Torque	Nm	12	32	32	32	40	40	40	40
Length (L)	mm	27.5	35	35	35	44.5	44.5	44.5	44.5
No. of Stage		1	2	2	2	3	3	3	3
Efficiency	%	96	94	94	94	90	90	90	90



Hall Sensor: SS41 Honeywell
<http://www.inovamicro.com/support/SS41.pdf>

Encoder Parameters				
Part No: -OEenn		-OE500	-OE1000	-OE2500
Resolution	PPR	500	1000	2500
Power Supply	V	5	5	5
Max Frequency	KHz	125	125	125
Index Pulse		Yes	Yes	Yes

Motor Connector (AMP 172168-1)						
Pin	1	2	3	4	5	6
Color	YL	GN	-	BU	BK	-
Signal	U	V	-	W	SHD	-

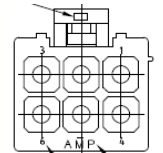

Motor Connectors (AMP 172168-1)
http://www.inovamicro.com/support/172168_1.pdf

Hall Sensor Connector (AMP 794617-6)						
Pin	1	2	3	4	5	6
Color	GB	YL	BK	YB	GN	WH
Signal	0V	U	SHD	5V	V	W

Encoder Connector (AMP 794617-6)						
Pin	1	2	3	4	5	6
Color	BK	GY	BK	RD	BN	OR
Signal	0V	A	SHD	5V	B	I

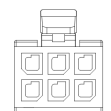

Sensor Connectors (AMP 794617-6)
<http://www.inovamicro.com/support/micromatenlock.pdf>

Order Information					
Model No	-Voltage	-Gearbox	-Feedback Device	-Brake	- Customized Code
BLM-4260	-24	-4P4	-OE1000		

Please find the ordering options from the Part No in the parameter tables above. For customizations, please contact sales@inovamicro.com

Driver Electronics	
Part Number	
iMOTO-1	http://www.inovamicro.com/imoto.html
iMOTO-2	http://www.inovamicro.com/imoto.html